

# ML27 T

## TELESCOPIC REACH SMALL ARTICULATED LOADER



OPERATING WEIGHT	
Open cab	5,732 lb (2600 kg)

OVERALL DIMENSIONS	
Overall height	92.1 in (2339 mm)
Overall length:	
Without bucket	136.5 in (3468 mm)
Machine width	60.0 in (1523 mm)

LOADER PERFORMANCE SPECS	
Lifting height	99.1 in (2517 mm)
Tipping load – Straight (Retracted)	6,405 lbs (2905 kg)
ROC 50% Tipping Load, Straight, Retracted:	3202 lbs (1452 kg)
Articulated, Retracted:	2717 lbs (1232 kg)

ELECTRICAL	
System voltage	12 volts
Alternator	60 amp
Battery	77 AHR 780 cold-cranking amps

ENGINE	
Model	Kubota D1803 CR
Emissions certification	Tier 4 Final/Stage V
Cylinders	4
Displacement	111.4 in <sup>3</sup> (1.826 L)
Fuel	Diesel
Exhaust aftertreatment	DOC + DPF
Engine speeds	RPM
Rated – full load	2,700
Horsepower @ 2,700 RPM – SAE J1349:	
Gross	50 hp (37.0 kW)
Peak torque @ 1,600 RPM	111.0 lb-ft (150.5 N-m)

DRIVETRAIN	
Transmission type	Hydrostatic, 2 speed
Differential type	Open Center w/ Diff Lock
Parking brake:	
Type	Drum
Max. travel speed	
Turtle	6.2 mph (9.9 kph)
Rabbit	18.6 mph (30 kph)

HYDRAULICS	
Control valve type	Open center
Pump type	Fixed gear
Driving hydraulics:	
Flow rate	32.0 gpm (121 L/min)
Operating pressure	5,800 psi (400 bar)
Auxiliary 1:	
Max. flow rate	13.5 gpm (51 L/min)
Pressure	3,300 psi (230 bar)
Auxiliary 2 – optional:	
Max. flow rate	13.5 gpm (51 L/min)
Pressure	3,300 psi (230 bar)
High flow – optional:	
Max. flow rate	21.0 gpm (79 L/min)
Pressure	3,300 psi (230 bar)

SERVICE CAPACITIES	
Fuel tank	7.9 gal (30 L)
Engine oil w/ filter	6.7 qt (6.3 L)
Hydraulic system	11.1 gal (42 L)
Engine coolant	1.7 gal (6.35 L)

## Standard Equipment

### Operator Environment

- ROPS/FOPS safety roof
- Safety entry bar
- Key start
- Mechanical suspension vinyl seat
- Armrests
- Retractable seat belt
- Exterior mirrors

### Engine

- Glow plug starting aid
- Engine block heater
- Locking fuel cap
- Cyclone air filter

### Drivetrain

- Hydrostatic 4-wheel drive
- FNR control on joystick
- Limited Slip w/Diff Lock
- Drum brakes
- Oscillation lock-out

### Hydraulics

- 3-spool main control valve
- 1x dual acting auxiliary hydraulics
- Attachment case drain return
- Loader arm float
- Oil cooler

### Loader

- Telescoping boom
- Standard lift path
- Mechanical self leveling
- Loader lift arm support strut
- SSL compatible attachment coupler, hydraulic powered
- Additional counterweights

### Electrical

- 12 volt system
- 77 AHR, 780 CCA battery
- 60 A alternator
- 2 front cab work lights
- 1 boom worklight
- Battery disconnect switch
- Anti-theft protection with access code
- Jump start provision

### Other Standard Features

- Recovery Hook
- Backup alarm
- Horn
- Fleet Force Telematics with 5-Year Advanced Connectivity

### Warranty

- Base warranty coverage: 2-Year/1,000-Hour Full Machine Limited Warranty

## Optional Equipment

### Operator Environment

- Enclosed cab with heat
- Heated Air suspension seat

### Engine

- Hand throttle

### Drivetrain

- Pro inching creep control

### Hydraulics

- 2x dual acting auxiliary hydraulics
- Auxiliary hydraulic hold function
- High flow auxiliary hydraulics
- Hydraulic boom suspension (ride control)

### Electrical

- 2 rear cab work lights
- 2 Boom Work Lights
- Road Lights/Turn Signals
- 14-pin electrical auxiliary connection
- Rotating beacon light
- 4-Corner Strobe light

### Other

- English, Spanish, or French operator manual
- Fender Extension

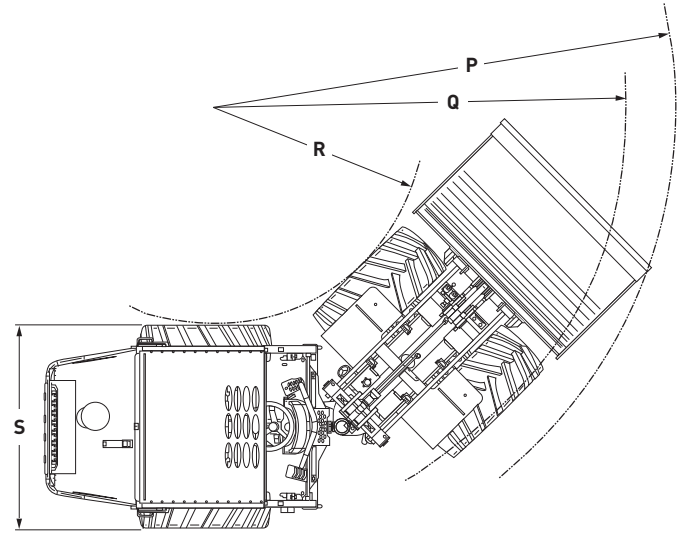
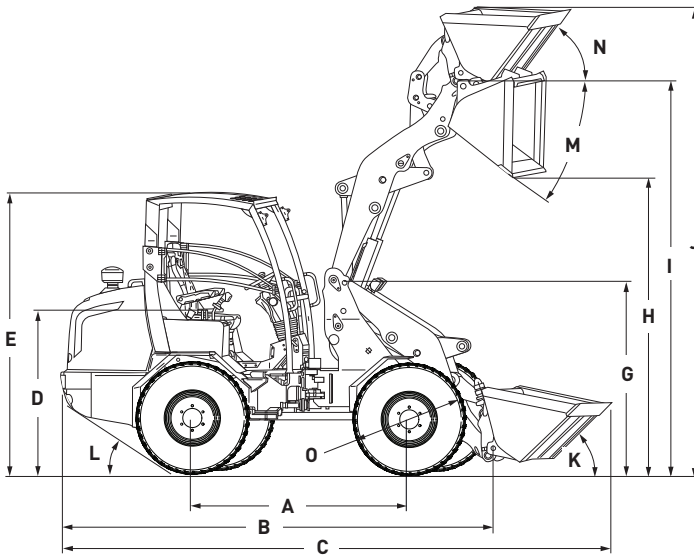

### DIMENSIONS

<b>A</b>	Wheelbase	66.9 in [1700 mm]
<b>B</b>	Total length	136.5 in [3468 mm]
<b>C</b>	Length with bucket	166.9 in [4239 mm]
<b>D</b>	Seat height	54.3 in [1380 mm]
<b>E</b>	Max. height with safety roof	92.5 in [2350 mm]
<b>F</b>	Max. height with cabin	92.5 in [2350 mm]
<b>G</b>	Height front frame	60 in [1420 mm]
<b>H</b>	Max. dumping height extended	114 in [2920 mm]
<b>I</b>	Lifting/hinge pin height	146 in [3710 mm]
<b>J</b>	Height with bucket	169 in [4 290 mm]
<b>K</b>	Rollback angle on the ground	41°
<b>L</b>	Rollback angle at max. lift height	50°
<b>M</b>	Max. dumping angle	35°
<b>N</b>	Max. loading angle	24°
<b>O</b>	Outer size of tires	34.3 in [871 mm]
<b>P</b>	Maximum radius external	44.9 in [1140 mm]
<b>Q</b>	Turning radius on outer edge	119.9 in [3045 mm]
<b>R</b>	Inner turning radius	103.3 in [2623 mm]
<b>S</b>	Width on standard tires	56 in [1410 mm]

### TIPPING LOADS

<b>T</b>	6,406 lb (2905 kg)
<b>U</b>	4,850 lb (2200 kg)
<b>V</b>	3,530 lb (1600 kg)
<b>W</b>	2,700 lb (1225 kg)
<b>X</b>	6,610 lb (3000 kg)
<b>Y</b>	4,410 lb (2000 kg)
<b>Z</b>	3,480 lb (1580 kg)

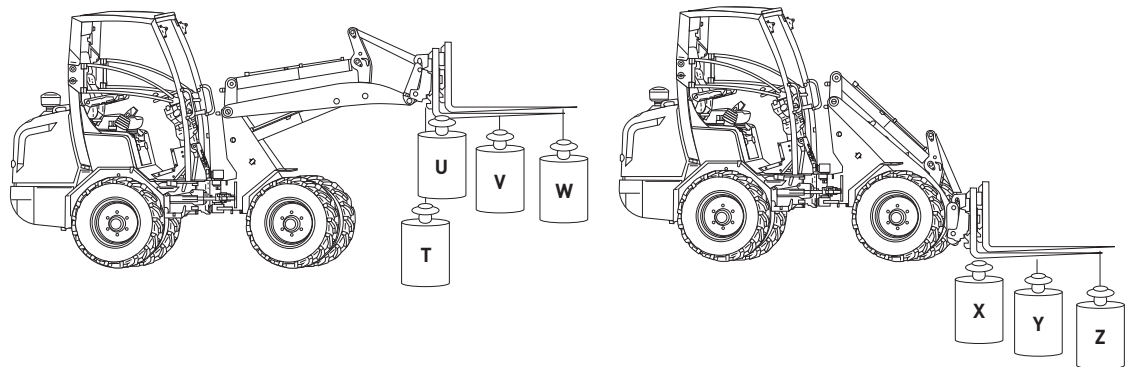

Line drawings are for illustrative purpose only and may not be exact representation of unit.



New Holland Construction  
500 Diller Ave.  
New Holland, PA 17557

Learn more at [www.newholland.com](http://www.newholland.com)



Design, materials and/or specifications are subject to change without notice and without liability therefor. Specifications are applicable to units sold in Canada, the United States, its territories and possessions, and may vary outside these areas.

© 2024 CNH Industrial America LLC. All rights reserved. New Holland is a trademark registered in the United States and many other countries, owned by or licensed to CNH Industrial N.V., its subsidiaries or affiliates. Any trademarks referred to herein, in association with goods and/or services of companies, other than owned by or licensed to CNH Industrial N.V., its subsidiaries or affiliates, are the property of those respective companies.



Safety begins with a thorough understanding of the equipment. Always make sure you and your operators read the Operator's Manual before using the equipment. Pay close attention to all safety and operating decals and never operate machinery without all shields, protective devices and structures in place.

NHC7130240617 • 0624 • OTP • PRINTED IN U.S.A.